



SKIOLD DAMAS OMEGA



SKIOLD MAKES THE DIFFERENCE!

Function

The illustration shows an example of Omega with feeding arrangement and recycling presuction system, screen section, and recycling aftersuction system. However, many other configurations exist.

Feed/presuction

As will appear from "Survey of models", there are 3 options of feeding/presuction arrangements:

- Drum feeding module type "O" is without presuction.
- Module "E" with drum feeding and open presuction.
- Module "R" has 2 distributor worms over the feed roller and frequency controlled and highly effective recycling cross flow air separation system.

Please consult "Selection of Feeding/Presuction and Discharge/Aftersuction" for the selection of feeding/presuction system.

OMEGA 121 IRR

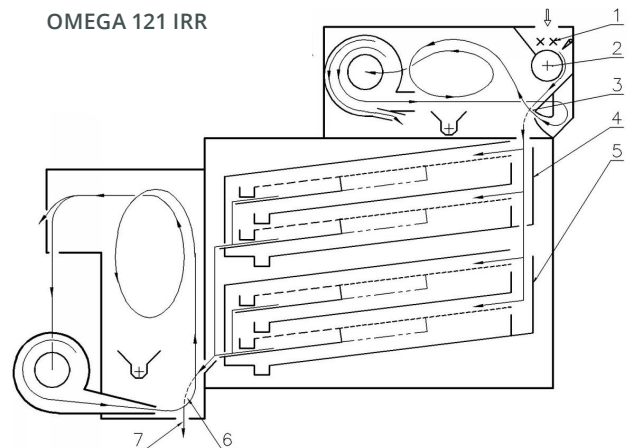

SKIOLD DAMAS OMEGA

Screen section

As will appear from "Screen flows and Guiding Capacities", 6 different screen flows (I - VI) with different advantages are available.

Please consult "Omega standard Screen flows and Guiding Capacities" for selection of screen flow.

Discharge/aftersuction

As will also appear from "Survey of models", there are 3 options of discharge/aftersuction arrangements:

- Discharge module "O" is just a discharge hopper without any aftersuction.

- Discharge module "E" features an open aftersuction system with aspiration compartment and auger for discharge of light waste.
- Discharge module "R" has a frequency controlled and highly effective recycling cross flow air separation system.

Please consult "Selection of feeding/Presuction and Discharge/ Aftersuction" for the selection of discharge/ aftersuction solution.

TECHNICAL SPECIFICATIONS

Screen specifications	9x1xx	12x1xx	18x1xx	24x1xx	30x1xx
Screen width (mm):	1250	1250	1250	1250	1250
No. of screens (pcs.):	9	12	18	24	30
Screen area (m ²):	9	12	18	24	30
Motors					
Feed roller(R, E, O) (kW):	0.75	0.75	0.75	2×0.75	2×0.75
Presuction R fan, grain (standard)** (kW):	3.0	3.0	3.0	-	-
Presuction R fan, peas/grain (special)** (kW):	5.5	5.5	5.5	-	-
Presuction R aspiration worm (kW):	0.37	0.37	0.37	-	-
Screen module, type 1 (kW):	7.5	5.5	7.5	7.5	15.0
Screen module, types 2, 3, or 4 (kW):	-	4.0	7.5	7.5	11.0
Aftersuction E aspiration worm (kW):	0.37	0.37	0.37	2×0.37	2×0.37
Aftersuction R fan, grain (standard)** (kW):	3.0	3.0	3.0	2×3.0	2×3.0
Aftersuction R fan, peas/grain (special)** (kW):	5.5	5.5	5.5	2×5.5	2×5.5
Aftersuction R aspiration worm (kW):	0.37	0.37	0.37	2×0.37	2×0.37
Air amounts					
Presuction E*** (m ³ /h):	4000	4000	4000	2×4000	2×4000
Presuction R** (m ³ /h):	800	800	800	-	-
Feeding module O (m ³ /h):	300	300	300	300	300
(Exhaust from the screen box)* (m ³ /h):	(300)	(300)	(300)	(300)	(300)
Aftersuction E*** (m ³ /h):	4000	4000	4000	2×4000	2×4000
Aftersuction R** (m ³ /h):	800	800	800	2×800	2×800
Weight					
Including modules E + O (kg):	3300	3500	3900	4300	4500
Including modules E + E (kg):	3600	3800	4200	4600	4800
Including modules R + O (kg):	3200	3400	3800	4200	-
Including modules R + R (kg):	4200	4400	4800	5200	-
Including modules E + R (kg):	-	-	-	-	5200

* Non-standard, ** Including frequency converter, *** Air amount = 5000 m³/h when cleaning peas and beans